



Life - Health - Happiness

Under Counter Alkaline Water Ionizer

User Manual

Model

VS-30

VS-50

VS-70



- Before using the instrument, be sure to carefully read through the instructions contained in this manual.
- The PH-value mentioned in this manual and panels varies depend on different water quality.
- Chanson shall not be liable for any malfunctions or accidents occurred from the user's ignorance and misuse during installation cause.

The Feature And Benefit Of Alkaline Water Ionizer

What are the benefits of alkaline water ionizer

1. Alkaline water ionizer is an antacid. Antacids help to treat the acid of human body to prevent from ill and chronic disease.
2. Alkaline water ionizer function as an antioxidant and seeks out free radicals to prevent from ill and chronic disease.
3. Alkaline electrolyzed water increases the Lactobacillus count and improves fermentation.
4. The water ionizer molecule structure (groups of H₂O molecules) size is reduced. It is easy to be absorbed by drinking and accelerates the metabolism to keep you young and healthy.
5. There're more minerals in alkaline water ionizer than ordinary water to satisfy daily mineral requirement.
6. Acid water could be used for beauty salon 、 face washing 、 and antibacterial purpose.

Suggestions for drinking alkaline water ionizer

1. The first section of alkaline water : The PH-value lies between 8.0 and 8.5, It's for first time to drinking and should range between 20-35 years old.
 2. The second section of alkaline water : The PH-value lies between 8.5 and 9.0, It's for that people used to drink alkaline water and also good for people of ages of 35-45 years old.
 3. The third section of alkaline water : The PH-value lies between 9.0 and 9.5 , for ages range above 45 years old and daily drinking. It's good to Improve some chronic diseases.
 4. The forth section of alkaline water : The PH-value lies between 9.5 and 10 , for food cleaning and odors.
 5. The first section of acid water : The PH-value lies between 5.0 and 6.0 and it's light acid. for skin cleaning and making pores smaller.
 6. The second section of acid water : The PH-value lies between 2.9 and 4.0 and it's mild acid, for dish washing 、 and antibacterial purpose.
- ※ You can benefit most from drinking alkaline water when :
 - (1) You feel hungry before meals.
 - (2) Between half hour before meals and 2 hours after meals.
 - ※ It influences the process electrolytic cell that most public water supplies provide hard water. please clean and care the electrolytic cell periodically.

Contents

1. Safety and misuse warnings	Page 2~3
.....	
2. Accessories and required tools	Page 4
.....	
3. Product overview after installment	Page 5
.....	
4. Installment explanation	Page 6~8
.....	
5. The instruction of measuring PH The instruction of replacing filters Using the tank for calcium powder	Page 9
.....	
6. VS-30/50/70 water faucet directions	Page 10
.....	
7. VS-30/50/70 functions	Page 11~13
.....	
8. VS-30/50/70 LCD functions guideline	Page 14~17
.....	
9. VS-30/50/70 LCD display directions	Page 18~20
.....	
10. VS-30/50/70 specification	Page 21
.....	
11. The process during blackout and water suspension	Page 22
.....	
12. VS-30/50/70 simple trouble shooting guidelines	Page 23
.....	
13. Filter maintenance record	Page 24~25

Safety Precautions MUST follow the instructions.

Read carefully the instructions contained in this manual.

Please follow the instructions below to prevent the misuse and avoid injury to the user and other persons as well as damage to property.

► If instructions ignored and applied incorrectly, creates the injury or damage which is labeled by the following symbols.

► Please follow the instructions below.



Warning

This symbol indicates warning that, if ignored or applied incorrectly, creates the danger of death or serious personal injury.



This symbol (⊘) means that the indicated action must not be performed. Indications within or nearby this symbol are specifically prohibited.



Caution

This symbol stipulates matters that have the risk of causing death or serious injury if the product is operated incorrectly while ignoring this indication.



This symbol (ⓘ) means that the indicated action must be performed.



Warning

Decompilation or disassembly is prohibited. Don't try to disassemble, maintenance, rebuild, or alter by yourself.



To disassemble creates the risk of fire and electric shock.

Please clean the dust or dirt over the outlet periodically.



If the dirt or dust from getting on the outlet, that will create the risk of electric shock by humidity.

Avoid multi-socket and household extension cords. Do not over voltage.



Using multi-socket and household extension cords can create the risk of fire by heating.

Do not damage power cord and outlet.



- Positioning by brad nails.
- Power cord was worn.
- Rebuild or alter by yourself.
- Twist or bend the power cord.
- Pull on the power cord
- Put heavy weight on power cord.
- Bend power cord as loop

Keep using worn power cord or outlet creates the risk of fire, electric shock, and short circuit.

Do not touch socket with wet hands.



That creates the risk of electric shock and injury.

Power plug must be plugged in completely



Do not use worn socket and loose plug.

Do not use unqualified water.



Water without anti-bacteria process or moving the hazard material out creates the risk of ill. Qualified water supply is recommended.

If device fall into water, please unplug from the electrical socket and stop using.



Please contact your original retailer or an authorized service provider.

Safety Precautions MUST follow the instructions.

Caution

Do not drink the water which pH-value is over 10.



That will create the risk of injury. The water which pH-value is around 9.5 is recommended. The third section of alkaline water is also recommended.



Before the first appliance of each day, please let the water flow freely about 0.6 liter (about 15 seconds) and then begin to use.

※ Over two days, please let the water flow freely about 8 liter (about 3 minutes) and then begin to use.

Avoid using aluminium containers which anti-alkali ability is weak. Avoid using copper containers without anti-acid ability



Using such containers will cause them to discolor or to be worn.



As chlorine in water is removed, it's easy to be added to cause injury.

For electrolyzed alkaline water or clean water, please store it at clean closed containers. Drink up in 1 day at normal temperature. Drink up in 2 days for storing at refrigerator.

Do not use unqualified water.



· strong alkaline water (PH10) and acid water.
· Water from drainage pipe
· Water from outlet during electrode cleaning
※ May cause uncomfortable feeling.



May cause water leakage and water pipe burst because of high pressure.

If pre-filter is installed and being absent without producing electrolyzed alkaline water more than 2 days, MUST turn off the water inlet switch.

The following persons should contact doctor before using weak acid water.



· Low skin resistance .
· With over-sensitive skin.



To drink highly alkaline water may cause uncomfortable feeling.

For drinking electrolyzed alkaline water for the first time, please drink 1 or 2 cups of the first section of alkaline electrolyzed water daily. After 2 weeks and body can accept alkaline electrolyzed water, then drink the second or the third section of alkaline electrolyzed water.

Do not use hot water with the temperature over 40 through pre-filters or device.



That may cause the damage of filters and device.



Contact our service providers about fees of the related maintenances.









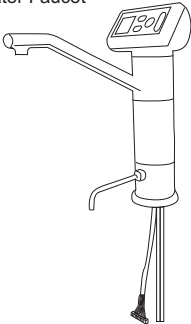

In a hard-water area, electrodes cannot function properly. Avoid being dysfunctional and losing of water quality, please clean and maintenance periodically.

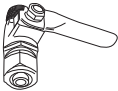
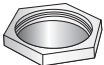
※ If go out over one day or absent without using water ioniter more than one day, must turn off power and water inlet switch.

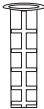
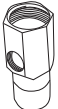
Accessories :

Before you use them, please match the accessories you have with the pictures below.
If there is any accessory missing, please ask your dealer for it.
Each kind of machine gets different kinds of accessories, please match and confirm.

The accessories for this machine.

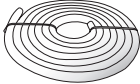
<p>Water Faucet</p> 	<p>Faucet Lock</p> 	<p>Trisection valve switch</p> 	
	<p>Base Nut</p> 	<p>PH value measurement fluid</p> 	
<p>Calcium powder additive bucket</p> 	<p>Quartile hexagonal union tee</p> 	<p>Soft hose clip (x2)</p> 	<p>Faucet washer (33x51x2)</p> 
<p>Back Hanging Set (used to stabilize the hanging section at the back) (additional purchase required)</p> 	<p>Plastic anchors x2 (additional purchase)</p> 	<p>Stabilizing nails x2 (additional purchase)</p> 	<p>150cm hard tube</p> 

Required Tools

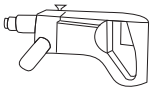
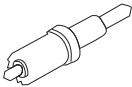
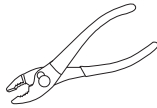
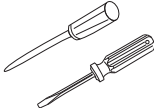
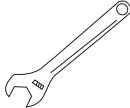
<p>① Electric drill</p> 	<p>② Cyclone drill heads (35mm),</p> 	<p>③ Slip Joint Pliers</p> 	<p>④ Phillips screwdrivers Slotted screwdriver</p> 	<p>⑤ Wrenches</p> 
--	--	--	--	--

Product Overview After Installment

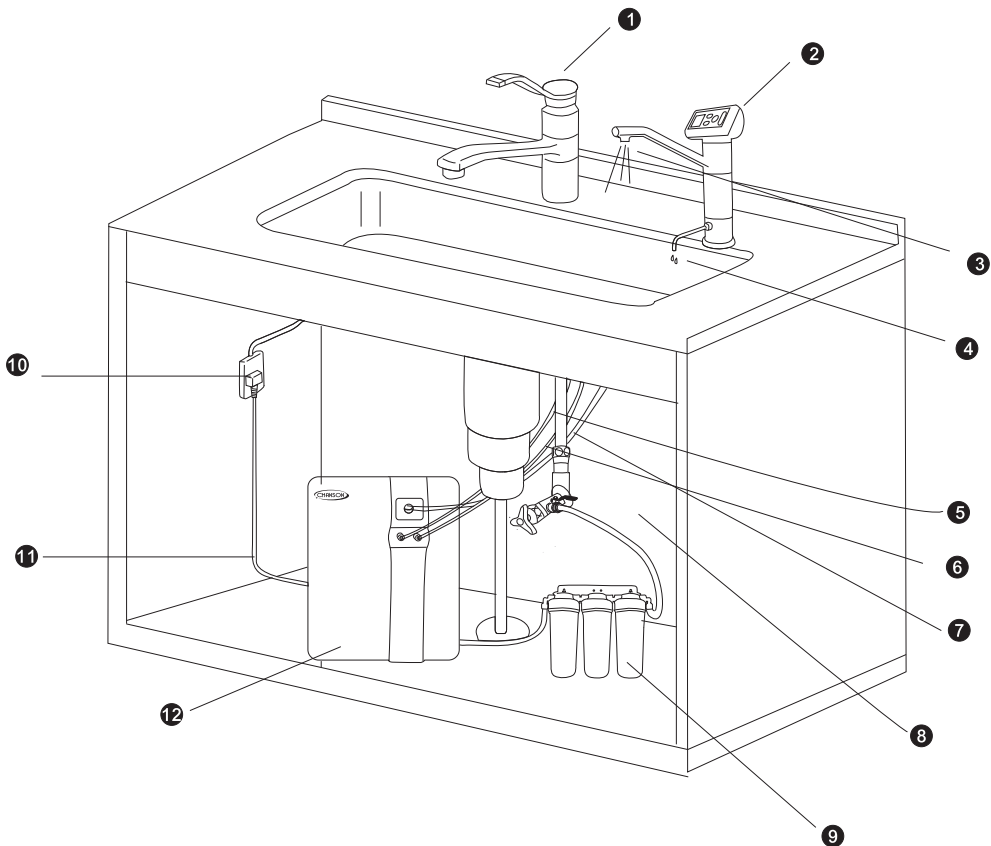

Product Components

1.	Water fauce (not included with the product)	2.	Open relief faucet	3.	Alkaline water exit
4.	acid water, water drain	5.	acid water pipe	6.	alkaline water pipe
7.	signal passage line	8.	water pipe	9.	Three-stages pre-filters (purchased separately)
10.	electric socket	11.	power line	12.	Mainframe

Installment Explanation

I. Hole-drilling For Faucet Installment

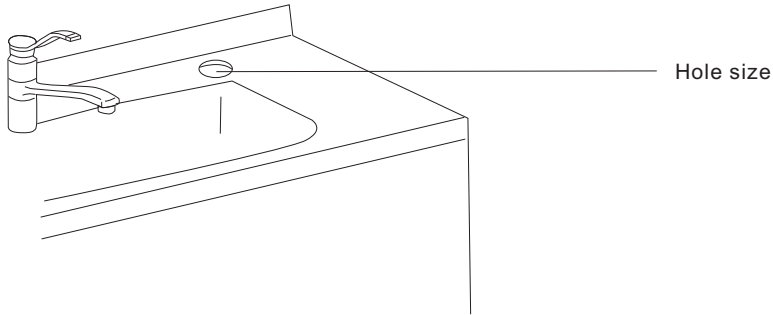

Procedures

1. Select the area needed for the drill hole and mark it.
2. Use the handhold drill and install the 35mm cyclone drill head.
3. Proceed with drilling at the selected location

II. The Connection Between The Water Source And The Mainframe.

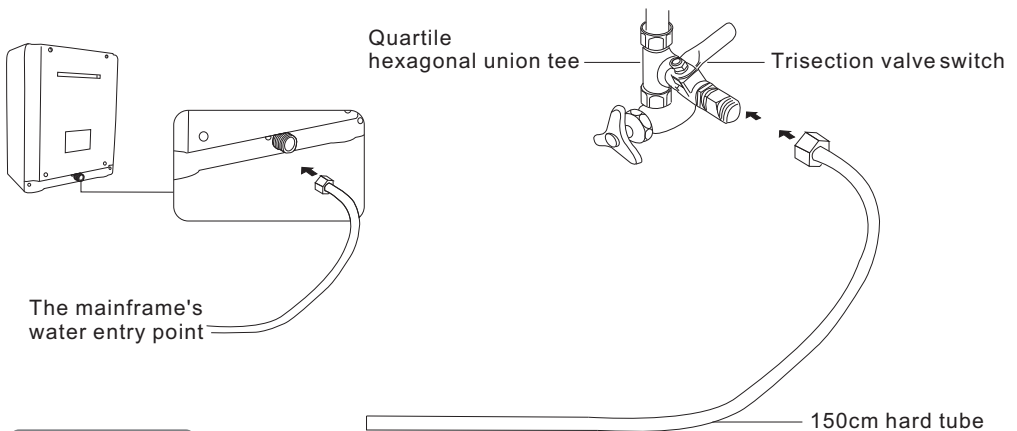

Procedures

1. Turn the water off.
2. Connect the quartile hexagonal union tee and the trisection valve switch together according to the correct order.
3. Cut the 150cm hard tube into suitable size, and then connect one end to the mainframe (if a pre-filter is installed, the water entry point should be installed first at the pre-filter) as the other end is connected to the trisection valve switch.

Installment Explanation

III. Faucet And Machine

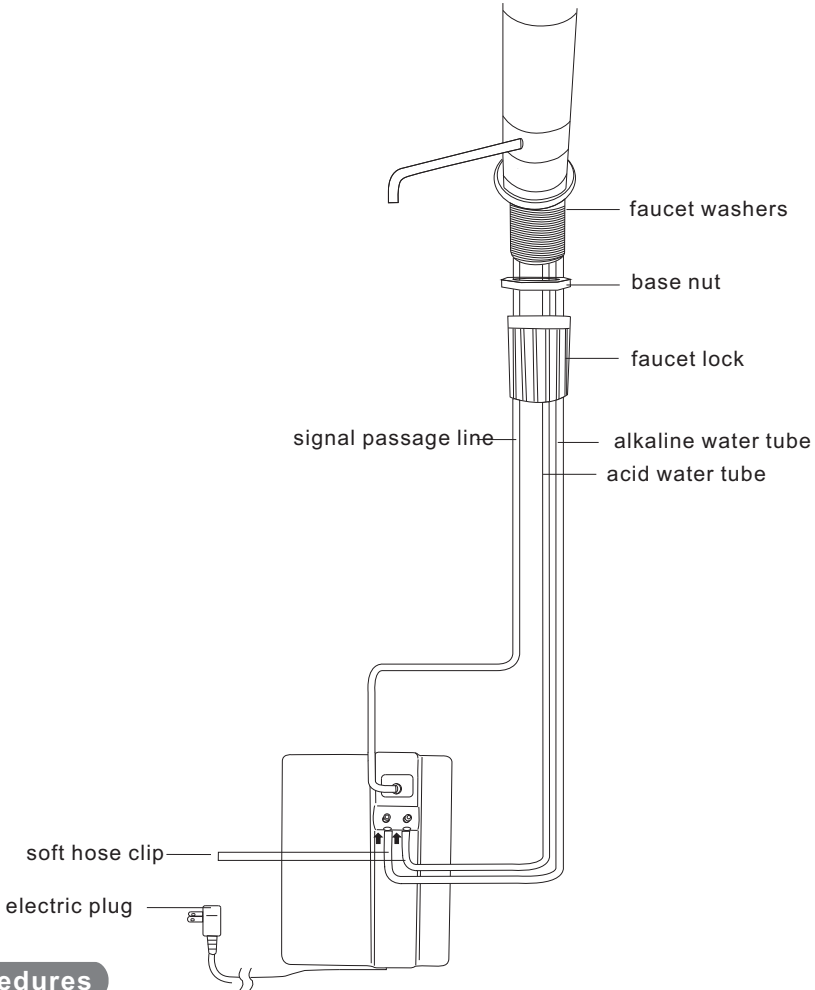

Procedures

1. Place the faucet and the washers into the drilled hole according to the required sequence, and pull the water tubes and the signal passage line under the basin.
2. Put the base nut on the faucet lock and pull the water tubes and the signal passage line through the faucet lock and lock it from the bottom to the top anticlockwise.
3. Clip the tube marked alkaline water to the alkaline water exit point on the machine.
4. Clip the tube marked acid water to the acid water exit point on the machine.
5. Connect the faucet signal passage line to the transfer hole of the machine.
6. Plug the power cord into the socket.
7. Turn the trisection valve switch on.

Instruction Of The Back Of Device

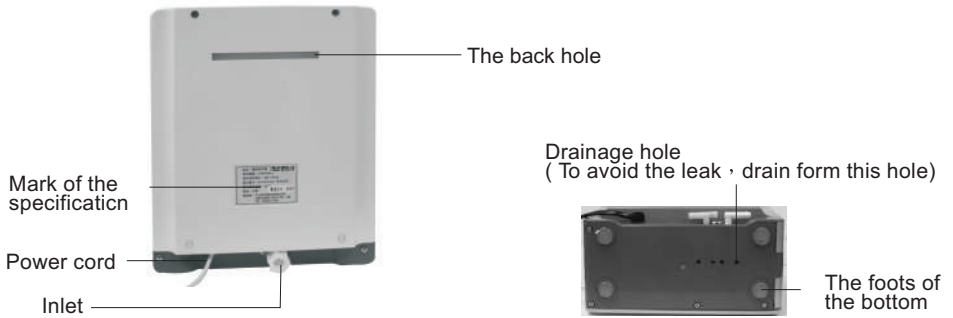

How To Mount The Device On Wall

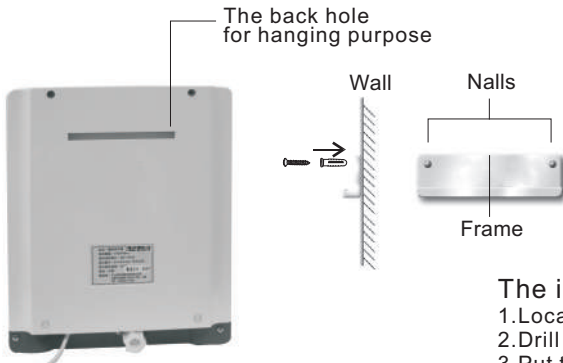

The instruction of installation

1. Locate the hole positions of frame on the wall.
2. Drill the hole on the wall.
3. Put the plastic anchors in the holes.
4. Tighten the nails in bolts.
5. Put the device on the aluminum frame.
6. All procedures are finished.

The Instruction Of Measuring PH

The following is the measuring procedure

1. Find the dropping bottle of PH indicator dye in accessory package. Two drops of the dye is added to a test tube.
2. Let the generated water flows freely for 10 seconds (for precise sampling).
3. Add some sampled water in the test tube. Cover and mix well.
4. In a bright environment, PH-value is determined visually by visual comparison with standard color charts.



Caution

Do not splash in eyes, taste, or swallow

- If swallowed. Drink water to dilute concentration. If in eyes, flush eyes with plenty of water. Seek medical aid immediately.
- Must cover the bottle tightly. And put it in a place where children cannot reach.
- PH indicator dye have a 1-year life cycle. If necessary,
- Please contact the nearest dealer.

The Instruction Of Replacing Filters

The procedure of replacing filters

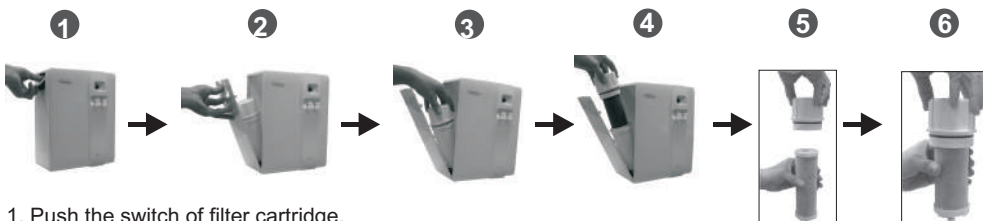

1. Push the switch of filter cartridge.
2. Pull up the filter cartridge.
3. Wrench out the top cap of filters bottle.
4. Take out the filter.
5. Rotate the top cap anticlockwise to remove filter.
6. Put a new filter and rotate clockwise to tighten.
7. Put the filter into the bottle and tighten the top cap.
8. Pull the switch of filter cartridge.
9. Reset the counter (Please refer to page 13 for the reset counter procedure.)
10. After flowing water freely for 1~2 minutes, the device is ready.

Using The Tank For Calcium Powder

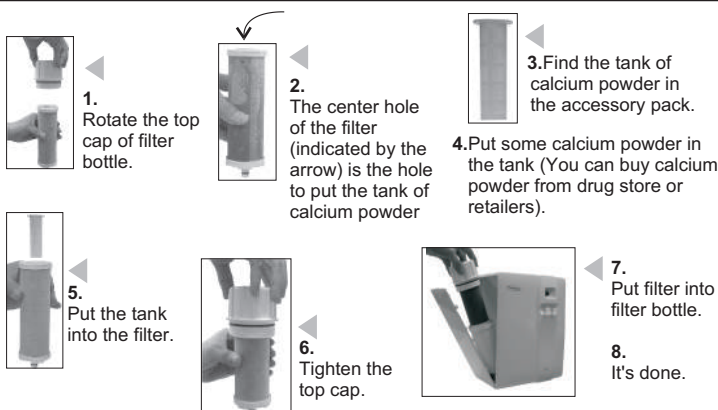

Tips :

1. The purpose of adding calcium powder is for improving soft-water in order to reach the desired pH-value. (In a hard-water area, it's not recommend to add that.)
2. Before adding calcium powder, MUST clean the tank to prevent from the aggregate of powder. It may cause dirt in water or aggregate on the electrode.

VS-30/50/70 Water Faucet Directions

Using The Control Panel



The instruction of alkaline water

※The pH-value mentioned in the table may vary depend on different water quality and different water pressure.

Alkaline water		PH-value
Usage		
High electrolyzed	Fruit cleaning : remove insecticides. Dishes cleaning : remove oil sludge Clothes cleaning : remove stains on the collars	Over 10
High alkaline	Remove the odor of kelp and burdock. Rice and vegetables are more delicious.	About 9.5-9.7
Standard alkaline	It's for daily drinking and also good for chronic disease to improve the uncomfortable feeling about stomach, constipation, diarrhea, and gout and prevent from aging.	About 9.0-9.5
Mid alkaline	It's good for people used to drink alkaline electrolyzed water and also good for people of 35-45 years old. The taste is more abundant for tea or coffee brewing. And improve the uncomfortable feeling of the tiredness and shortage of sleep.	About 8.5-9.0
Low alkaline	It's for people to drink for the first time. It's also good for people of 20-35 years old. To balance of acid and alkaline and prevent from aging.	About 8.0-8.5

Clean water	
Filtering water	It's for preparing milk or taking medicine.

Acid water		PH-value
Usage		
Low acid	It's for deep cleaning beneath the skin's surface and deep pore cleaning.	About 5.0-5.5
High acid	It's anti-bacteria for floor cleaning, dishes cleaning.	About 2.9-4.0

VS-30/50/70 Functions

Operation Guidelines

1. When you are going to obtain drinking water, please press the water on/off button. At this time the water indication light will turn "purple". Then you are able to get water when the light turns "blue."
2. When you are intending to turn the water off, press the water on/off button to shut the water off. At the same time the power light will turn red, and be on hold.
3. When you turn on the water each time, (if the water quality is not lock) the water quality level will be set at " standard alkaline ". If you wish to adjust the water quality level, you can press the "+ -" button to select your desired water quality level then press the "confirm" button to get the water.
4. Every time when you finish using the equipment, the liquid crystal display will continue to be on for 60 seconds. Then it will enter the sleep (electric saving) mode after 60 seconds and the screen will go blank.

VS-30/50/70 Functional Directions

PH Value Micro Adjustment Express Button Operation Guidelines.

Function direction

This function can micro adjust the PH value in the water. For example: If your water quality level is set at " standard alkaline " and the default setting of the machine is at PH9.5 while you wish to increase or reduce the value, you can use the express button to adjust the PH value to micro adjust the water quality. There are ten levels of PH micro adjustment to increase or decrease from 0.1~0.5.

Operation direction (Under the circumstances of water being available)

1. Press the water on/off button to eject water. Then wait until the water indicator light is on "blue" to press the "function" button to enter the menu.
2. Press the "+-" button to select the "PH set" screen.
3. Please press the "confirm" button again to use the "+-" button to increase or decrease the PH value.
4. After micro adjust the PH value you desired, then press the "confirm" button to complete the setting.

VS-30/50/70 Functions

Water Quality Express Button Operation Guidelines

Functional directions

The "Lock" function can hold the water quality level you desired. For example : If you want to drink "mid alkaline" water for a long period of time, after you apply the LOCK function, you are able to get "mid alkaline" quality of water every time you turn on the faucet. This function can prevent seniors or children from drinking the water at a dangerous level.

Operation directions (Under the circumstances of water being available)

I. Water Quality Lock Express Button Operation :

1. Locking the water quality:

After pressing the water on/off button, wait until the water indication light turns "blue" then press on the "confirm" button for 2 seconds. After that, the word LOCK will appear on the upper right corner of the LCD for confirming the lock on the water quality.

2. Disengage water quality lock:

When the water is running, and when the water indication light is on "blue," continue to press on the "confirm" button for 2 seconds. The LOCK on the LCD will disappear, and the water lock is disengaged.

II. Water Quality Lock Express Button Operation :

1. Locking the water quality.

- A. Press the water on/off button and wait until the power indication light turns "blue," and then press on the "MENU" button to enter the menu.
- B. Press the "+-" button to select the LOCK Option.
- C. Press the "confirm" button again to complete the lock of the water quality.

2. Disengage lock option:

- A. When the water is running, and the power indication light is "blue," press the "menu" button to enter the menu.
- B. Press the "+-" button to select the "LOCK" Option.
- C. Press on "confirm" again to disengage the LOCK option.

Vs-30/50/70 Functions

Adjustable Functions Through LCD Touchable Panel

Liquid Crystal Display Adjustable Function Items		Default Setting
Time	Display the adjustable time and number	00:00
Lock	Able to lock onto your desired water quality	disengaged
PH set	Able to adjust the PH water quality to suit your needs 1.(+) increase 0.1~0.5 2(-) decrease 0.1~0.5	
Filter reset	Reset the filter count to zero.	
Volume set	Adjust the Volume. (+) increase (-) decrease.	
Language option	Select (Chinese, Simplified Chinese, English)	English
Voice assistant	Select (Chinese, English, Music)	English
Exit	Exit the function setting	

VS-30/50/70 LCD Functions Guideline

Operation Guideline

Liquid Crystal Display

Setting items

operating without connecting water

- 1 Press "MENU" button to enter.
- 2 Press "+" button to adjust the setting and press the "confirm" button to complete.
- 3 Press "+" button to adjust the setting and press the "confirm" button to complete.
- 4 Press "+" button to get to the exit and press the "confirm" button to exit or wait for 5 seconds and it will exit automatically.

Time

Example :
for setting the time to 15:58

Time

Time

15:00

adjust the hour when
the hour is blinking.

5:58

adjust the minutes
when the minutes
section is blinking.

Time

Time will return to
waiting screen after
3 seconds.

Lock

Example :
wanting to set the lock on the
water quality

Time

Lock

Low alkaline

select level?

Return to the waiting
screen and the word LOCK
is displayed on the top right
corner of the screen.

15 : 58

waiting screen

Automatically turned off
after 60 seconds
(energy saving mode).

Lock

15 : 58

waiting screen

Automatically turned off
after 60 seconds
(energy saving mode).

VS-30/50/70 LCD Functions Guideline

Liquid Crystal Display

PH set

Example :
The water quality is set at "alkaline 3"
and wishing to adjust the PH level
from 9.5 to 9.8.

Time

PH set

Standard
alkaline

select level?

PH
9.5

PH
9.8

return immediately to the
waiting screen shown below
and the standard alkaline's
PH level will be locked as 9.8

15 : 58

waiting screen

Automatically turned off
after 60 seconds
(energy saving mode).

Filter reset

Example :
For wanting to reset the filter
counter to zero

Time

Filter reset

Confirm

Return immediately to the
waiting screen shown below:

15 : 58

waiting screen

Automatically turned off
after 60 seconds
(energy saving mode).

Volume set

Example :
For wanting to adjust the volume

Time

Volume set



(+) increase (-) decrease

Volume set

return to waiting screen
after 3 seconds.

15 : 58

waiting screen

Automatically turned off
after 60 seconds
(energy saving mode).

VS-30/50/70 LCD Functions Guideline

Operation Guideline

Operation items

operating without connecting water

- 1 Press "menu" button to enter.
- 2 Press "+-" button to adjust the setting and press the "confirm" button to complete.
- 3 Press "+-" button to adjust the setting and press the "confirm" button to complete.
- 4 Press "+-" button to get to the exit and press the "confirm" button to exit or wait for 5 seconds and it will exit automatically.

Liquid Crystal Display

※Only available music on vs70

Language option

Example :
for wanting to set the language to "English"

Time

Language option

Traditional Chinese
English
Simplified Chinese

Language option

return immediately to the waiting screen shown below after 3 seconds.

Voice assistant

Example :
For wanting to set the voice to music

Time

Voice assistant

Chinese
English
Music

Voice assistant

return immediately to the waiting screen shown below after 3 seconds.

15 : 58

waiting screen

Automatically turned off after 60 seconds (energy saving mode).

15 : 58

waiting screen

Automatically turned off after 60 seconds (energy saving mode).

VS-30/50/70 LCD Functions Guideline

Liquid Crystal Display

Exit

Example :
For wanting to exit the setting

Time

Exit

return immediately to the
waiting screen shown below

15 : 58

waiting screen

Automatically turned off
after 60 seconds
(energy saving mode).

VS-30/50/70 LCD Display Directions

LCD Display Directions

Star-up images



startup image



Scenic View



water quality level display



water quality level picture



PH value display



Filter lifetime display



time display

Electrode plate self cleaning

※Please refer to page 11 for the procedures of self clean the electrode plate.



Water cell



Water cell

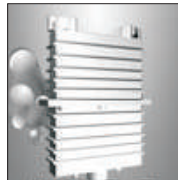

Complete

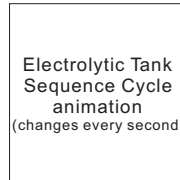

time display

※Return to waiting screen when it is complete.

VS-30/50/70 LCD Display Directions

Water Quality Level And Screen Display Guidelines



※the PH value, filter lifespan value are simulation displays.

VS-30/50/70 LCD Display Directions

Water Quality Level And Screen Display Guidelines

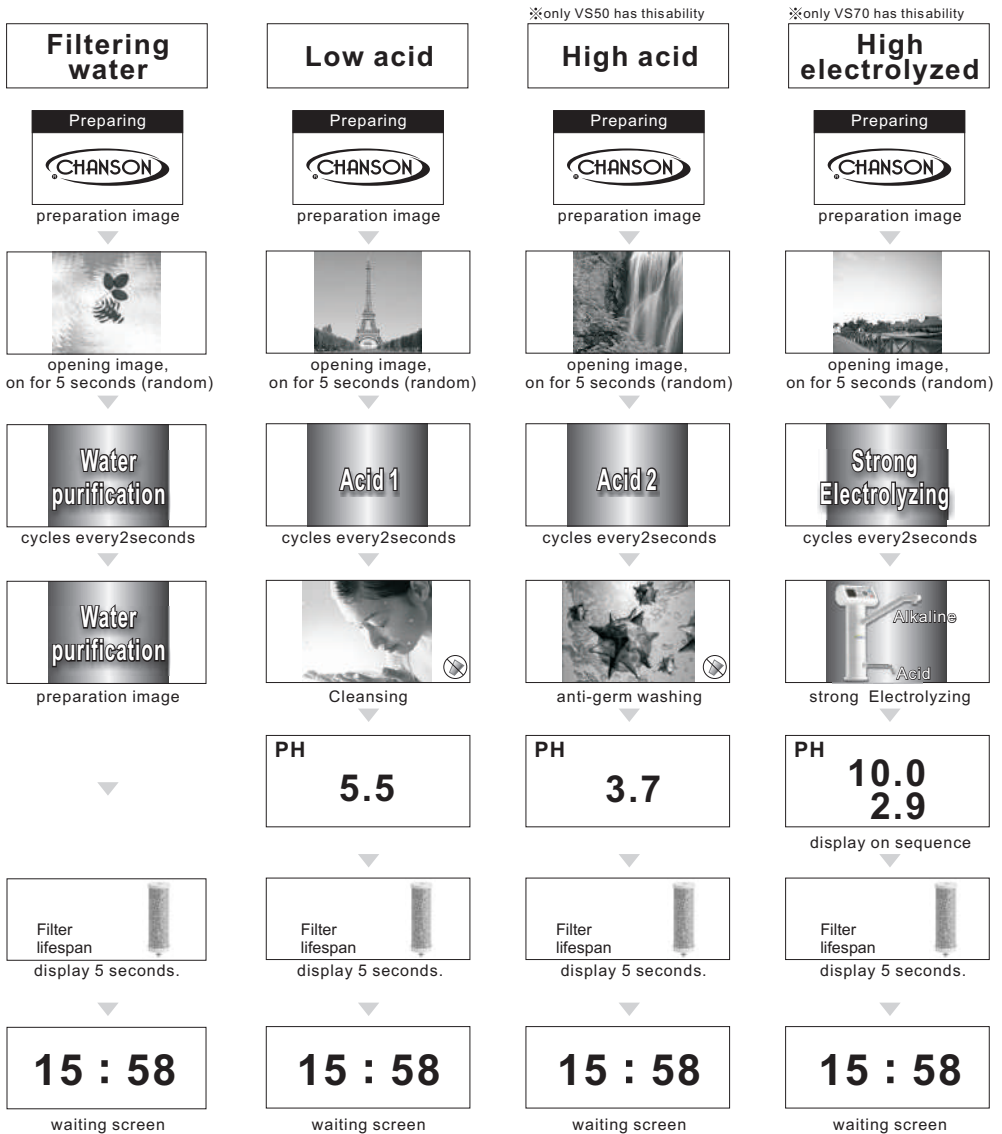

※the PH value, filter lifespan value are simulation displays.

VS-30/50/70 Specification

Model	VS-30	VS-50	VS-70
Voltage	110V/60Hz	110V/60Hz	110V/60Hz
LCD / Machine / Faucet Width*Height*depth (mm)	LCD / 22.5*33*12 Machine / 22.5*33*12 Faucet / 210*80*280	LCD / 22.5*33*12 Machine / 22.5*33*12 Faucet / 210*80*280	LCD / 22.5*33*12 Machine / 22.5*33*12 Faucet / 210*80*280
Weight (kg)	About 5.5	About 5.7	About 5.9
Number of electrode	3	5	7
Consumed power (Watt)	3~150	3~150	3~150
The display of cleaning	LCD display	LCD display	LCD display
Sections of water quality	4 sections of alkaline water	4 sections of alkaline water	4 sections of alkaline water
	1 section of clean water	1 section of clean water	1 section of clean water
	1 section of acidwater	2 section of acidwater	2 section of acidwater
LCD display	260,000 color TFT Colorful screen	260,000 color TFT Colorful screen	260,000 color TFT Colorful screen
The display of remain life of filter	LCD display	LCD display	LCD display
The material of filter	Lead-Removing & Sliver-Adding Fiber Activated Carbon	Lead-Removing & Sliver-Adding Fiber Activated Carbon	Lead-Removing & Sliver-Adding Fiber Activated Carbon
The display of pH-value	●	●	●
Voice	●	●	●
High electrolyzed alkaline			●

The Process During Blackout And Water Suspension

During blackout

1. When blackout occurs during operation, please first turn off the water faucet.
2. After the electricity returns, please begin operation according to the normal procedure.
3. When blackout occurs, your settings (not including time setting), filter lifespan is still in the machine's memory.

During water suspension :

1. When water suspension occurs during operation, please turn off the trisection valve switch.
2. When the water returns, let the tap water to run for 1-2 minutes. This is because to allow the air and dirt to exit the water pipe. If air or dirt remain in the main filter, it will greatly reduce the filter's lifespan.

VS-30/50/70 Simple Trouble Shooting Guidelines

Malfunction,
warning image

The cause for malfunction and trouble
shooting method



Water temperature too high

The water temperature from the water input is too high.

- ▶ Turn the water off immediately, and make sure the water from the intake is below 40 degrees C before using.

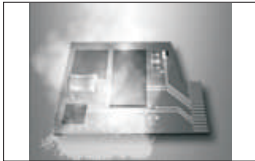

Machine overheating

Machine's temperature too high.

- ▶ Please shut down the machine and rest for 30 minutes before reusing. If the machine doesn't start-up again, contact your retail service center to handle it.



Abnormality in the electrolytic cell

1, excessive current.

- ▶ 2 .no electric current coming out (electrolytic cell protection device). please contact your retail service center to handle it.



Increase water flow

- ▶ input water flow is too weak. Increase the water flow and adjust the valve on the water faucet.



Decrease water flow

- ▶ input water flow is too strong. Decrease the water flow and adjust the valve on the water faucet.

Filter Maintenance Record

Items Date	(Pre-filter) The first filter	(Pre-filter) The second filter	(Pre-filter) The third filter	Inner filter	Maintenance of Electrode tank

Filter Maintenance Record

Items Date	(Pre-filter) The first filter	(Pre-filter) The second filter	(Pre-filter) The third filter	Inner filter	Maintenance of Electrode tank

Chanson Series For Water Purification

- Counter Top Alkaline Water Ionizer
- Under Counter Alkaline Water Ionizer
- Reverse Osmosis Water Purifiers
 - Ozone Air Cleaners
 - Ceramic Water Purifiers



CHANSON WATER Co., LTD

DEALER :